

3)

Exploration**The Monopolar Quantum Relativistic Electron: An Extension of the Standard Model & Quantum Field Theory (Part 3)**Anthony Bermanseder¹**Abstract**

In this paper, a particular attempt for unification shall be indicated in the proposal of a third kind of relativity in a geometric form of quantum relativity, which utilizes the string modular duality of a higher dimensional energy spectrum based on a physics of wormholes directly related to a cosmogony preceding the cosmologies of the thermodynamic universe from inflaton to instanton. In this way, the quantum theory of the microcosm of the outer and inner atom becomes subject to conformal transformations to and from the instanton of a quantum big bang or qbb and therefore enabling a description of the macrocosm of general relativity in terms of the modular T-duality of 11-dimensional supermembrane theory and so incorporating quantum gravity as a geometrical effect of energy transformations at the wormhole scale.

Part 3 of this article series includes: A Mapping of the Atomic Nucleus onto the Thermodynamic Universe of the Hyperspheres; The Higgsian Scalar-Neutrino; & The Wave Matter of de Broglie.

Keywords: Monopolar, quantum relativity, Standard Model, extension, quantum field theory.

A Mapping of the Atomic Nucleus onto the Thermodynamic Universe of the Hyperspheres

We consider the universe's thermodynamic expansion to proceed at an initializing time $t_{ps}=f_{ss}$ at lightspeed for a light path $x=ct$ to describe the hypersphere radii as the volume of the inflaton made manifest by the instanton as a lower dimensional subspace and consisting of a summation of a single spacetime quantum with a quantized toroidal volume $2\pi^2 r_{weyl}$ and where $r_{weyl}=r_{ps}$ is the characteristic wormhole radius for this basic building unit for a quantized universe (say in string parameters given in the Planck scale and its transformations).

At a time t_G , say so 18.85 minutes later, the count of space time quanta can be said to be 9.677×10^{102} for a universal 'total hypersphere radius' of about $r_G=3.391558005 \times 10^{11}$ meters and for a G-Hypersphere volume of so 7.69×10^{35} cubic meters from $N\{2\pi^2 \cdot r_{ps}^3\} = \text{Volume} = 2\pi^2 \cdot R_{HK3}$.

¹ Correspondence: Anthony Bermanseder, Independent Researcher. E-mail: omniphysics@cosmosdawn.net

3)

{This radius is about 2.3 Astronomical Units (AU's) and about the distance of the Asteroid Belt from the star Sol in a typical (our) solar system.}

This modelling of a mapping of the quantum micro-scale onto the cosmological macro-scale can then be used to indicate the mapping of the wormhole scale onto the scale of the sun as a quasiconformal scaling of the fermi scale of the classical electron radius onto a typical gravitational star system. $r_{\text{weyl}}/R_{\text{sun}}=R_e/r_E$ for $R_{\text{sun}}=r_{\text{weyl}}.r_E/R_e=1,971,030$ meters. This gives an 'inner' solar core of diameter about 3.94×10^5 meters.

As the classical electron radius is quantized in the wormhole radius in the formulation $R_e=10^{10}r_{\text{weyl}}/360$, rendering a fine structure for Planck's Constant as a 'superstring parametric': $h=2\pi r_{\text{weyl}}/2R_e c^3$; the 'outer' solar scale becomes $R_{\text{sun}[o]}=360.R_{\text{sun}}=7.092 \times 10^8$ meters as the observed radius for the solar disk.

19 seconds later; a F-Hypersphere radius is about $r_F=3.451077503 \times 10^{11}$ meters for a F-count of so 1.02×10^{103} spacetime quanta for the thermodynamically expanding universe from the instanton. We also define an E-Hypersphere radius at $r_E=3.435971077 \times 10^{14}$ meters and an E-count of so 10^{112} to circumscribe this 'solar system' in so 230 AU.

We so have 4 hypersphere volumes, based on the singularity-unit and magnified via spacetime quantization in the hyperspheres defined in counters G, F and E. We consider these counters as somehow fundamental to the universe's expansion, serving as boundary conditions in some manner.

As counters, those googol-numbers can be said to be defined algorithmically and to be independent on mensuration physics of any kind.

{<https://cosmosdawn.net/index.php/en...stanton-to-continuoon-four-pillars-of-creation>}

Should we consider the universe to follow some kind of architectural blueprint; then we might attempt to use our counters to be isomorphic (same form or shape) in a one-to-one mapping between the macro-cosmos and the micro-cosmos.

So we define a quantum geometry for the nucleus in the simplest atom, say Hydrogen. The hydrogenic nucleus is a single proton of quark-structure udu and to which we assign a quantum geometric template of Kernel-Inner Ring-Outer Ring (K-IR-OR), say in a simple model of concentricity.

We set the up-quarks (u) to become the 'smeared out core' in say a tripartition uuu so allowing a substructure for the down-quark (d) to be u+Inner Ring (IR).

A down-quark so is a unitary ring coupled to a kernel-quark. The proton's quark-content so can be rewritten and without any loss of any of the properties and generalities in unitary symmetry obtained from the Standard Model of particle physics and associated with the quantum

3)

conservation laws; as proton \Rightarrow udu \Rightarrow uuu+IR = KKK+IR. We may now label the Inner Ring as Mesonic and the Outer Ring as Leptonic.

The Outer Ring (OR) is so definitive for the strange quark in quantum geometric terms: s=u+OR. A neutron's quark content so becomes neutron=dud=KIR.K.KIR with a 'hyperon resonance' in the lambda=sud=KOR.K.KIR and so allowing the neutron's beta decay to proceed in disassociation from a nucleus (where protons and neutrons bind in meson exchange); i.e. in the form of 'free neutrons'.

The neutron decays in the oscillation potential between the mesonic inner ring and the leptonic outer ring as the 'ground-energy' eigenstate.

There actually exist three uds-quark states which decay differently via strong, electromagnetic and weak decay rates in the uds (Σ^0 Resonance); usd (Σ^0) and the sud (Λ^0) in increasing stability.

This quantum geometry then indicates the behaviour of the triple-uds decay from first principles, whereas the contemporary standard model does not, considering the u-d-s quark eigenstates to be quantum geometrically undifferentiated.

The nuclear interactions, both strong and weak are confined in a 'Magnetic Asymptotic Confinement Limit, coinciding with the Classical Electron Radius $R_e = ke^2/m_e c^2$ and in a scale of so 3 Fermi or 2.8×10^{-15} meters. At a distance further away from this scale, the nuclear interaction strength vanishes rapidly.

The wave nature of the nucleus is given in the Compton-Radius $R_{\text{compton}} = h/2\pi mc$ with m the mass of the nucleus, say a proton; the latter so having a scale reduced from R_e by some partitioning of the classical electron size.

As the Planck Oscillator $E_o = \frac{1}{2}hf_o$ of the Zero-Point-Energy or ZPE as Vortex-Potential-Energy or VPE defines its ground state at half its effective energy of $E_k = hf_k$, and as a conformal mapping from the string energy scale of the inflaton onto the qbb scale of the instanton in the $E_{\text{weyl}} = E_{\text{ps}} = e^* = 1/2R_e c^2|_{\text{mod}}$ gauge boson; we define a subatomic scale at half of R_e as $r_{\text{mean}} = \frac{1}{2}R_e$.

The wave-matter (after de Broglie generalizing wave speed v_{dB} from c in $R_{\text{compton}}c$) then relates the classical electron radius as the 'confinement limit' to the Compton scale in the electromagnetic fine structure constant in $R_e = \text{Alpha} \cdot R_{\text{compton}}$.

The extension to the hydrogen-atom is obtained in the expression $R_e = \text{Alpha}^2 \cdot R_{\text{bohr}1}$ for the first Bohr-Radius as the 'ground energy' of so 13.7 eV at a scale of so 10^{-10} meters (Angstroems).

These 'facts of measurements' of the standard models now allow our quantum geometric correspondences to assume cosmological significance in their isomorphic mapping. We denote the

3)

Outer Ring as the classical electron radius and introduce the Inner Ring as a mesonic scale contained within the geometry of the proton and all other elementary baryonic- and hadronic particles.

Firstly, we define a mean macro-mesonic radius as: $r_M = \frac{1}{2}(r_F + r_G) = 3.421317754 \times 10^{11}$ meters and set the macro-leptonic radius to $r_E = 3.435971077 \times 10^{14}$ meters.

Secondly, we map the macro-scale onto the micro-scale, say in the simple proportionality relation for the micro-mesonic scale $R_{\text{mean}} = R_e \cdot r_M / r_E = 2.765931439 \times 10^{-18}$ meters.

So reducing the apparent measured 'size' of a halving of R_e in a factor about 1000 gives the scale of the sub-nuclear mesonic interaction, say the strong interaction coupling by pions.

The Higgsian Scalar-Neutrino

The (anti)neutrinos are part of the electron mass in a decoupling process between the kernel and the rings. Neutrino mass is so not cosmologically significant and cannot be utilized in 'missing mass' models'.

We may define the kernel-scale as that of the singular spacetime-quantum unit itself, namely as the wormhole radius $r_{\text{weyl}} = r_{\text{ps}} = 10^{-22} / 2\pi$ meters.

Before the decoupling between kernel and rings, the kernel-energy can be said to be strongweak coupled or unified to encompass the gauge-gluon of the strong interaction and the gauge-weakon of the weak interaction defined in a coupling between the leptonic Outer Ring and the Kernel and bypassing the mesonic Inner Ring.

So for matter, a W-Minus (weakon) must consist of a coupled lepton part yet linking to the strong interaction via the kernel part. If now the colour-charge of the gluon transmutes into a 'neutrino-colour-charge'; then this decoupling will not only define the mechanics for the strongweak nuclear unification coupling; but also the energy transformation of the gauge-colour charge into the gauge-lepton charge.

There are precisely 8 gluonic transitive energy permutation eigenstates between a 'radiative-additive' Planck energy in $W(\text{hite}) = E = hf$ and an 'inertial-subtractive'

Einstein energy in $B(\text{lack}) = E = mc^2$, which describe the baryonic- and hyperonic 'quark-sectors' in: $mc^2 = BBB, BBW, WBB, BWB, WBW, BWW, WWB$ and $WWW = hf$.

The permutations are cyclic and not linearly commutative. For mesons (quark-antiquark eigenstates), the permutations are BB, BW, WB and WW in the SU(2) and SU(3) Unitary Symmetries.

So generally, we may state, that the gluon is unified with a weakon before decoupling; this decoupling 'materializing' energy in the form of mass, namely the mass of the measured 'weak

3)

interaction-bosons' of the standard model (W^- for charged matter; W^+ for charged antimatter and Z^0 for neutral mass-currents say).

Experiment shows, that a W^- decays into spin-aligned electron-antineutrino or muon-antineutrino or tauon-antineutrino pairings under the conservation laws for momentum and energy.

So, using our quantum geometry, we realize, that the weakly decoupled electron must represent the Outer Ring, and just as shown in the analysis of QED (Quantum Electro-Dynamics). Then it can be inferred, that the Electron's Anti-neutrino represents a transformed and materialized gluon via its colour charge, now decoupled from the kernel and in a way revisiting the transformation of a bosonic ancestry for the fermionic matter structures, discussed further on in the string class transformations of the inflaton era. There exists so a natural and generic supersymmetry in the quark-lepton hierarchy and no additional supersymmetric particles are necessary.

Then the Outer Ring contracts along its magneto axis defining its asymptotic confinement and in effect 'shrinking the electron' in its inertial and charge- properties to its experimentally measured 'point-particle-size'.

Here we define this process as a mapping between the electronic wavelength $2\pi R_e$ and the wormhole perimeter $\lambda_{weyl}=2\pi r_{weyl}$.

But in this process of the 'shrinking' classical electron radius towards the gluonic kernel; the mesonic ring will be encountered and it is there, that any mass inductions should occur to differentiate a massless lepton gauge-eigenstate from that manifested by the weakon precursors. {Note: Here the W^- inducing a lefthanded neutron to decay weakly into a lefthanded proton, a lefthanded electron and a righthanded antineutrino. Only lefthanded particles decay weakly in CP-parity-symmetry violation, effected by neutrino-gauge definitions from first principles}.

This then indicates a neutrino-oscillation potential at the Inner Ring-Boundary. Using our proportions and assigning any neutrino-masses m_ν as part of the electron mass m_e , gives the following proportionality as the mass eigenvalue of the Tau-(Anti)Neutrino as Higgsian Mass Induction in the Weak Nuclear Interaction at the Mesonic Inner Ring Boundary within the subatomic quantum geometry utilized as the dynamic interaction space:

$$m_{\text{Higgs/Tauon}} = m_e \lambda_{weyl} \cdot r_E / (2\pi r_M R_e) = m_e \lambda_{weyl} \cdot r_E / (2\pi r_M R_e) \sim 5.345878435^{-36} \text{ kg}^* \text{ or } 2.994971267 \text{ eV}^* \dots\dots\dots [\text{Eq.13}]$$

So we have derived, from first principles, a (anti)neutrino mass eigenstate energy level of 3 eV as the appropriate energy level for any (anti)neutrino matter interaction within the subatomic dynamics of the nuclear interaction.

This confirms the Mainz, Germany Result (Neutrino 2000), as the upper limit for neutrino masses resulting from ordinary Beta-Decay and indicates the importance of the primordial beta decay for the cosmogenesis and the isomorphic scale mappings referred to in the above. The hypersphere

3)

intersection of the G- and F-count of the thermodynamic expansion of the mass parametric universe so induces a neutrino-mass of 3 eV* at the $2.765931439 \times 10^{-18}$ meter marker. The more precise G-F differential in terms of eigenenergy is 0.052 eV as the mass-eigenvalue for the Higgs-(Anti)neutrino (which is scalar of 0-spin and constituent of the so-called Higgs Boson as the kernel-Eigenstate). This has been experimentally verified in the Super-Kamiokande (Japan) neutrino experiments published in 1998 and in subsequent neutrino experiments around the globe, say Sudbury, KamLAND, Dubna, MinibooNE and MINOS.

Recalling the Cosmic scale radii for the initial manifestation of the primordial 'Free Neutron (Beta-Minus) Decay', we rewrite the Neutrino-Mass-Induction formula:

$r_E = 3.435971077 \times 10^{14}$ meters and an E-count of $(26 \times 65^{61}) = 1.00 \times 10^{112}$ spacetime quanta:

$m_{\nu\text{Higgs-E}} = m_{\text{velectron}} = m_e \cdot r_{ps} \{r_E/r_E\}/R_e = 5.323079952 \times 10^{-39}$ kg* or 0.00298219866 eV* as Weak Interaction Higgs Mass induction.

But in this limiting case the supermembrane modular duality of the instanton identity $E_{ps} \cdot e^* = 1$ applied to the Compton constant will define the limiting neutrino mass for the electron as a modular neutrino mass per displacement quantum defined in the Compton constant and for a modulation displacement factor $\{R_e^2/r_{ps}\}$:

$$|m_{\nu\text{Higgs-E}} = m_{\text{velectron}}|_{\text{modular}} = m_e \cdot r_{ps} \{R_e^2/r_{ps}\}/R_e = \alpha \cdot h/2\pi c = 2.580701988 \times 10^{-45} \text{ (kg/m)*} \dots \dots \dots [\text{Eq.14}]$$

$r_F = 3.451077503 \times 10^{11}$ meters for the F-count of $(13 \times 66^{56}) = 1.02 \times 10^{103}$ spacetime quanta: $m_{\nu\text{Higgs-F}} = m_{\nu\text{muon}} = m_e \cdot r_{ps} \{r_F/r_F\}/R_e = 5.299779196 \times 10^{-36}$ kg* or 2.969144661 eV* as Weak Interaction Higgs Mass induction.

$r_G = 3.39155805 \times 10^{11}$ meters for the G-count of $(67 \times 36^{65}) = 9.68 \times 10^{102}$ spacetime quanta: $m_{\nu\text{Higgs-G}} = m_{\nu\text{tauon}} = m_e \cdot r_{ps} \{r_G/r_G\}/R_e = 5.392786657 \times 10^{-36}$ kg* or 3.021251097 eV* as Weak Interaction Higgs Mass Induction.

The mass difference for the Muon-Tauon-(Anti)Neutrino Oscillation, then defines the Mesonic Inner Ring Higgs Induction:.....[Eq.15] $m_{\nu\text{Higgs}} = m_e \cdot r_{ps} \{r_E/r_G - r_E/r_F\}/R_e = 9.3007461 \times 10^{-38}$ kg* or 0.05210643614 eV* as the Basic Cosmic (Anti)Neutrino Mass.

This Higgs-Neutrino-Induction is 'twinned' meaning that this energy can be related to the energy of so termed 'slow- or thermal neutrons' in a coupled energy of so twice 0.0253 eV for a thermal equilibrium at so 20° Celsius and a rms-standard-speed of so 2200 m/s from the Maxwell statistical distributions for the kinematics.

3)

The (anti)neutrino energy at the R_E nexus for $R_E = r_{ps} \sqrt[3]{(26 \times 65^{61})} m^*$ and for $m_{\nu\text{Higgs-E}} = m_{\nu\text{electron}} = \mu_0 e^2 c^2 \cdot r_{ps} / 4\pi R_e^2 c^2 = 30e^2 \lambda_{ps} / 2\pi c R_e^2$ or $\mu_0 \{\text{Monopole GUT masses } ec\}^2 r_{ps} / 4\pi R_e^2 c^2 = 2.982198661 \times 10^{-3} \text{ eV}^*$ and for:

$$m_{\nu\text{Electron}} c^2 = m_{\nu} (v_{\text{Tauon}})^2 c^2 = m_{\nu} (v_{\text{Muon}}^2 + v_{\text{Higgs}}^2) c^2 = \mu_0 \{\text{Monopole GUT masses } ec\}^2 r_{ps} / 4\pi R_e^2$$

.....[Eq.16]

This can also be written as $m_{\nu\text{Higgs-E}} = m_{\nu\text{electron}} = m_{\nu\text{Tauon}}^2$ to define the 'squared' Higgs (Anti)Neutrino eigenstate from its templated form of the quantum geometry in the Unified Field of Quantum Relativity (UFoQR).

Subsequently, the Muon (Anti)Neutrino Higgs Induction mass becomes defined in the difference between the masses of the Tau-(Anti)Neutrino and the Higgs (Anti)Neutrino.

$$m_{\nu\text{Tauon}} = B^4 G^4 R^4 [0] + B^2 G^2 R^2 [-1/2] = B^6 G^6 R^6 [-1/2] = \sqrt{(m_{\nu\text{electron}})} = \sqrt{(0.002982)} = 0.0546... \text{ eV}^*$$

$$m_{\nu\text{Higgs}} = B^4 G^4 R^4 [0] = m_e \lambda_{ps} \cdot r_E \{1/r_G - 1/r_F\} / (2\pi R_e) \sim 9.301 \times 10^{-38} \text{ kg}^* \text{ or } 0.0521... \text{ eV}^*$$

$$m_{\nu\text{Muon}} = B^2 G^2 R^2 [-1/2] = \sqrt{(m_{\nu\text{Tauon}}^2 - m_{\nu\text{Higgs}}^2)} = \sqrt{(0.00298 - 0.00271)} = \sqrt{(0.00027)} = 0.0164... \text{ eV}^*$$

$$m_{\nu\text{Electron}} = B^2 G^2 R^2 [-1/2] = (m_{\nu\text{Tauon}})^2 = (0.054607...)^2 = 0.002982... \text{ eV}^*$$

This energy self-state for the Electron (Anti)Neutrino then is made manifest in the Higgs Mass Induction at the Mesonic Inner Ring or IR as the squared mass differential between two (anti)neutrino self-states as:

$$(m_{\nu 3} + m_{\nu 2}) \cdot (m_{\nu 3} - m_{\nu 2}) = m_{\nu 3}^2 - m_{\nu 2}^2 = 0.002981... \text{ eV}^{*2}$$

to reflect the 'squared' energy self-state of the scalar Higgs (Anti)Neutrino as compared to the singlet energy eigen state of the base (anti)neutrinos for the 3 leptonic families of electron-positron and the muon-antimuon and the tauon-antitauon.

The Electron-(Anti)Neutrino is massless as base-neutrino weakon eigenstate and inducted at R_E at 0.00298 eV^* .

The Muon-(Anti)Neutrino is also massless as base-neutrino weakon eigenstate and inducted at the Mesonic Ring F-Boundary at 2.969 eV^* with an effective Higgsian mass induction of 0.0164 eV^* .

All (anti)neutrinos gain mass energy however when they become decoupled from their host weakon; either a W^- for matter or a W^+ for antimatter. So as constituents of the weakon gauge for the weak interaction the electron- and muon (anti)neutrinos are their own antiparticles and so manifest their Majorana qualities in the weak interaction. Once emitted into the energy momentum spacetime however, the monopolar nature from their self-dual GUT/IIB monopole mass $[ec]_{\text{uimd}}$ or

3)

their energy [$ec^3=2.7 \times 10^{16} \text{ GeV}^*$]_{unifiedinmodularduality} manifests in their masses. The premise of the older Standard Model for a massless (anti)neutrino so remains valid for them in respect to their Majorana-coupling their lepton partners as the weakon agents in their quantum geometric templates; but is modified for 'free' (anti)neutrinos as Dirac particles.

The Tauon-(Anti)Neutrino is not massless with inertial eigenstate inducted at the Mesonic Ring G-Boundary at 3.021 eV* and averaged at 3.00 eV* as $\sqrt{(0.05212+0.01642)} = 0.0546 \text{ eV}^*$ as the square root value of the ground state of the Higgs inertia induction. The neutrino flavour mechanism, based on the Electron (Anti)Neutrino so becomes identical in the Weakon Tauon Electron-Neutrino oscillation to the Scalar Muon-Higgs-Neutrino oscillation.

The weakon kernel-eigenstates are 'squared' or doubled ($2 \times 2 = 2 + 2$) in comparison with the gluonic-eigenstate (one can denote the colour charges as $(R^2G^2B^2)[\frac{1}{2}]$ and as $(RGB)[1]$ respectively say and with the $[\]$ bracket denoting gauge-spin and RGB meaning colours Red-Green-Blue).

The scalar Higgs-Anti(Neutrino) becomes then defined in: $(R^4G^4B^4)[0]$ and the Tauon Anti(Neutrino) in $(R^6G^6B^6)[\frac{1}{2}]$.

The twinned neutrino state so becomes apparent in a coupling of the scalar Higgs-Neutrino with a massless base neutrino in a $(R^6G^6B^6)[0+\frac{1}{2}]$ mass-induction template.

The Higgs-Neutrino is bosonic and so not subject to the Pauli Exclusion Principle; but quantized in the form of the FG-differential of the 0.0521 Higgs-Restmass Induction. Subsequently all experimentally observed neutrino-oscillations should show a stepwise energy induction in units of the Higgs-neutrino mass of 0.0521 eV. This was the case in the Super-Kamiokande experiments; and which was interpreted as a mass differential between the muonic and tauonic neutrino forms.

$m_{\nu\text{Higgs}} + m_{\nu\text{electron}} = m_{\nu\text{Higgs}} + (m_{\nu\text{Tauon}})^2$ for the 'squared' ground state of a massless base (anti)neutrino for a perturbation Higgsian (anti)neutrino in $(m_{\nu\text{Tauon}})^2 = (m_{\nu\text{Higgs}} + \Delta)^2 = m_{\nu\text{Electron}}$ for the quadratic $m_{\nu\text{Higgs}}^2 + 2m_{\nu\text{Higgs}}\Delta + \Delta^2 = 0.002982$ from $(m_{\nu\text{Higgs}} + \Delta) = \sqrt{(m_{\nu\text{electron}})}$ and for a $\Delta = \sqrt{(m_{\nu\text{electron}})} - m_{\nu\text{Higgs}} = m_{\nu\text{Tauon}} - m_{\nu\text{Higgs}} = 0.0546 \text{ eV} - 0.0521 \text{ eV} = 0.0025 \text{ eV}$.

$m_{\nu\text{Higgs}} + \Delta = 0.0521 + 0.0025 = (m_{\nu\text{Higgs}}) + (m_{\nu\text{electron}}) - 0.00048 = m_{\nu\text{tauon}} = 0.0521 + 0.00298 - 0.00048 + \dots = 0.0546 \text{ eV}^*$ as a perturbation expression for the 'squared' scalar Higgs (Anti)Neutrino.

$(m_{\nu\text{Muon}} - m_{\nu\text{Electron}})\{(m_{\nu\text{Muon}} + m_{\nu\text{Electron}}) - (m_{\nu\text{Muon}} - m_{\nu\text{Electron}})\} = 2m_{\nu\text{Electron}}(m_{\nu\text{Muon}} - m_{\nu\text{Electron}})$ as the squared mass difference:

$$m_{\nu\text{Muon}}^2 - m_{\nu\text{Electron}}^2 = 2m_{\nu\text{Electron}}(m_{\nu\text{Muon}} - m_{\nu\text{Electron}}) + (m_{\nu\text{Muon}} - m_{\nu\text{Electron}})^2$$

3)

and for $m_{\nu\text{Muon}}^2 = m_{\nu\text{Electron}} - m_{\nu\text{Higgs}}^2 = (0.002982 - 0.00271 = 0.00027)$ for $\sqrt{(0.00027)} = m_{\nu\text{Muon}} = 0.01643 = 5.51 m_{\nu\text{Electron}}$.

$\{m_{\nu\text{Muon}}^2 - m_{\nu\text{Electron}}^2\} - m_{\nu\text{Muon}}^2 + 2m_{\nu\text{Muon}}m_{\nu\text{Electron}} - m_{\nu\text{Electron}}^2 = 2m_{\nu\text{Muon}}m_{\nu\text{Electron}} - 2m_{\nu\text{Electron}}^2 = 2m_{\nu\text{Electron}}\{m_{\nu\text{Muon}} - m_{\nu\text{Electron}}\} = 2m_{\nu\text{Electron}}^2\{m_{\nu\text{Muon}}/m_{\nu\text{Electron}} - 1\} = 8.892 \times 10^{-6}\{11.02 - 1\} = 8.910 \times 10^{-5}$, approximating the KamLAND 2005 neutrino mass induction value of $7.997 \dots \times 10^{-5}$ eV² obtained

for a ratio of $11m_{\nu\text{Electron}} = 2m_{\nu\text{Muon}}$.

For 3 (anti)neutrinos then, the cosmological summation lower and upper bounds for (anti)neutrino oscillations are:

$0 + m_{\nu\text{electron-muon}} + m_{\nu\text{electron-tauon}} + m_{\nu\text{muon-tauon}} = 3(0.002982) = 0.00895 \text{ eV}^*$ or 0.00893 eV [SI] and $3(0.0030+0.0546) = 3(0.0576) = 0.1728 \text{ eV}^*$ or 0.1724 eV [SI] respectively.

Inclusion of the scalar Higgs (anti)neutrino as a fourth (anti)neutrino inertial self-state extends this upper boundary by 0.0521 eV^* and 0.0520 eV to 0.2249 eV^* or 0.2243 eV [SI] .

$\sum m_{\nu} = m_{\nu\text{Electron}} + m_{\nu\text{Muon}} + m_{\nu\text{Higgs}} + m_{\nu\text{Tauon}} = 0.002982 \dots + 0.0164 \dots + 0.0521 \dots + 0.0546 \dots = 0.1261 \text{ eV}^*$ or 0.1258 eV .

In terms of the Higgs Mass Induction and so their inertial states, the Neutrinos are their own antiparticles and so Majorana defined; but in terms of their basic magneto charged nature within the Unified Field of Quantum Relativity, the Neutrinos are different from their Antineutrino antiparticles in their Dirac definition of $R^2G^2B^2[+1/2]$ for the Antineutrinos and in $B^2G^2R^2[-1/2]$ for the Neutrinos.

{s}	=	1.000978394	{s*}	=	0.999022562	{s}
{m}	=	1.001671357	{m*}	=	0.998331431	{m}
{kg}	=	1.003753126	{kg*}	=	0.996260907	{kg}
{C}	=	1.002711702	{C*}	=	0.997295631	{C}
{J}	=	1.005143377	{J*}	=	0.994882942	{J}
{eV}	=	1.00246560	{eV*}	=	0.997540464	{eV}
{K}	=	0.98301975	{K*}	=	1.017273559	{K}

3)

The Wave Matter of de Broglie: $\lambda_{deBroglie} = h/p$

The Wave matter of de Broglie from the Energy-Momentum Relation is applied in a (a) nonrelativistic, a (b) relativistic and a (c) superluminal form in the matter wavelength:

$$\lambda_{deBroglie} = h/p = hc/pc \text{ for } (pc) = \sqrt{\{E^2 - E_o^2\}} = m_o c^2 \cdot \sqrt{\{[v/c]^2/(1-[v/c]^2)\}}$$

(a) Example:

A pellet of 10g moves at 10 m/s for a de Broglie wavelength $\lambda_{dB} = h/mv = h/0.1 = 6.7 \times 10^{-33} \text{ m}^*$ This matter wavelength requires diffraction interference pattern of the order of λ_{dB} to be observable and subject to measurement

(b) Example:

An electron, moving at 80% of light speed 'c' requires relativistic development

$E_o = m_o c^2$ with $E = mc^2 = m_o c^2 / \sqrt{\{1-[v/c]^2\}}$, a 66.66% increase in the electron's energy describing the Kinetic Energy $E - E_o = \{m - m_o\}c^2$ for a relativistic momentum $p = m_o c \cdot \sqrt{\{[0.8]^2/(1-[0.8]^2)\}} = (1.333..) m_o c = h/\lambda_{deBroglie}$ and for a relativistic de Broglie wavelength, 60% smaller, than for the non-relativistic electron in $\lambda_{deBroglie} = h/1.333..m_o c < h/0.8m_o c = \lambda_{deBroglie}$ ($1.83 \times 10^{-12} \text{ m}$ relativistic and $3.05 \times 10^{-12} \text{ m}^*$ non-relativistic for an electron 'rest mass' of $9.11 \times 10^{-31} \text{ kg}^*$ and measurable in diffraction interference patterns with apertures comparable to this wave matter scale).

(c) The de Broglie matter wave speed in its 'group integrated' form derives from the postulates of Special Relativity and is defined in the invariance of light speed 'c' as a classical upper boundary for the acceleration of any mass M. In its 'phase-individuated' form, the de Broglie matter wave is 'hyper accelerated' or tachyonic, the de Broglie wave speed being lower bounded by light speed 'c' $v_{phase} = \text{wavelength} \cdot \text{frequency} = (h/mv_{group})(mc^2/h) = c^2/v_{group} > c$ for all $v_{group} < c$

$$m = \text{Energy}/c^2 = hf/c^2 = hc/\lambda_{deBroglie}c^2 = h/\lambda_{deBroglie}c = m_{deBroglie} = [\text{Action as}$$

$\text{Charge}^2]_{mod}/c(\text{Planck-Length Oscillation}) = [e^2]_{mod}/cI_{Planck}\sqrt{\alpha} = [e^2c^2/ce]_{mod} = [ec]_{modular}$ as monopole mass of GUT-string IIB and as string displacement current mass equivalent for the classical electron displacement $2R_e = e^*/c^2 = [ec]_{modular}$ as Wormhole minimum spacetime configuration for the Big Bang Instanton of Big Bang wormhole energy quantum

$E_{ps} = hf_{ps} = m_{ps}c^2 = kT_{ps}$ as a function of $e^* = 1/E_{ps}$ of Heterotic superstring class HE 8x8 and relating the Classical Electron Diameter $\{2R_e\}$ as Monopole Mass $[ec]_{mod}$ in mass $M = E/c^2$ modular dual in Curvature Radius $r_{ps} = \lambda_{ps}/2\pi = 2G_o M_c/c^2 \Rightarrow G_o m_{ps}/c^2$ quantum gravitationally.

3)

The factor $2G_0/c^2$ multiplied by the factor 4π becomes Einstein's Constant $\kappa = 8\pi G_0/c^2 = 3.102776531 \times 10^{-26}$ m/kg describing how spacetime curvature relates to the mass embedded in that spacetime in the theory of General Relativity coupled to the theory of Quantum Relativity.

The self-duality of the superstring IIB aka the Magnetic Monopole self-state in GUT Unification $2R_e/30[ec]_{\text{mod}} = 2R_e c^2/30[ec^3]_{\text{mod}} = e^*/30[ec^3]_{\text{mod}} \propto \kappa$ for a proportionality constant $\{\kappa^*\} = 2R_e/30\kappa[ec]_{\text{mod}} = 2R_e \cdot c^2/8\pi e = e^*/8\pi e = 1.2384 \dots \times 10^{20}$ kg*/m* in string units for Star Charge in Star Coulomb C*/Electro Charge in Coulomb C unified.

The monopolar Grand Unification (SEWG \Rightarrow sEWG \Rightarrow gravitational decoupling SEW.G) has a Planck string energy reduced at the IIB string level of $e^* = [ec^3]_{\text{modular}}$ for $m_{\text{ps}} c^2/[ec]_{\text{modular}} = [c^3]_{\text{modular}} = 2.7 \times 10^{25}$ eV* or 4.3362×10^6 J* for a monopole mass $[ec]_{\text{modular}} = m_{\text{monopole}} = 4.818 \times 10^{11}$ kg*.

Mass $M = n \cdot m_{\text{ss}} = \Sigma m_{\text{ss}} = n \cdot \{h/2\pi r_{\text{deBroglie}} c\} \cdot [E_{\text{ss}} \cdot e^*]_{\text{mod}} = n \cdot m_{\text{ps}} \cdot [E_{\text{ss}} \cdot \{9 \times 10^{60}\} \cdot 2\pi^2 R_{\text{rmp}}^3]_{\text{mod}} = n \cdot m_{\text{ps}} \cdot [E_{\text{ss}} \cdot \{2R_e \cdot c^2\}]_{\text{mod}} = n \cdot [E_{\text{ps}} \cdot E_{\text{ss}}]_{\text{mod}} \cdot [2R_e]_{\text{mod}}$ for $\lambda_{\text{deBroglie}} = \lambda_{\text{ps}} = h/m_{\text{ps}} c$ and $[E_{\text{ps}} \cdot e^*]_{\text{mod}} = 1$

$\{2R_e c^2\} = 4G_0 M_{\text{Hyper}}$ for the classical electron radius $R_e = ke^2/m_e c^2$ and describes its Hyper-Mass $M_{\text{Hyper-electron}} = R_e c^2/2G_0 = ke^2/2G_0 m_e = 1.125 \times 10^{12}$ kg* for an effective electron mass of $m_e = ke^2/2G_0 (1.125 \times 10^{12}) = 9.290527148 \times 10^{-31}$ kg* in string

units and where $k = 1/4\pi\epsilon_0 = [G_0]_u = [30c]_u = 9 \times 10^9$ (Nm²/C²)*.

The curvature radius for the electron mass $m_e = r_{\text{electron}} c^2/2G_0$ then becomes $r_{\text{electron}} = 2G_0 m_e/c^2 = 2.293957 \dots \times 10^{-57}$ m* in string-membrane inflaton space as $1.44133588 \times 10^{-34}$ r_{ps} in the wormhole instanton space.

$R_e/r_{\text{inflaton-electron}} = M_{\text{Hyper-electron}}/m_e = 1.2109108 \dots \times 10^{42} = 1/2(EMI/GI) = 1/2(e^2/G_0^2 m_e^2) = 1/2 \{e/G_0 m_e\}^2 = 1/2(2.421821677 \times 10^{42})$ for the classical electron radius R_e halved from the classical electron diameter $2R_e$ from the definition for the modulated supermembrane coupled in $E_{\text{ps}} E_{\text{ss}} = h^2$ and $E_{\text{ps}}/E_{\text{ss}} = f_{\text{ps}}^2 = 1/f_{\text{ss}}^2$.

Mass $M = n \cdot m_{\text{ss}} = \Sigma m_{\text{ss}} = n \cdot \{m_{\text{ps}}\} \cdot [E_{\text{ss}} \cdot e^*]_{\text{mod}} = n \cdot \{m_{\text{ps}}\} \{[hf_{\text{ss}}] \cdot 2\pi^2 R_{\text{rmp}}^3\}_{\text{mod}} = n \cdot [m_{\text{ps}} f_{\text{ss}}^2]_{\text{mod}} = n \cdot [hf_{\text{ss}}/c^2] = n \cdot m_{\text{ss}}$

$R_{\text{ps}} = \lambda_{\text{ps}}/2\pi$ as the wormhole radius of the Instanton as a conformally transformed Planck-Length $L_p = \sqrt{\{G_0 h/2\pi c^3\}}$ from the Inflaton.

3)

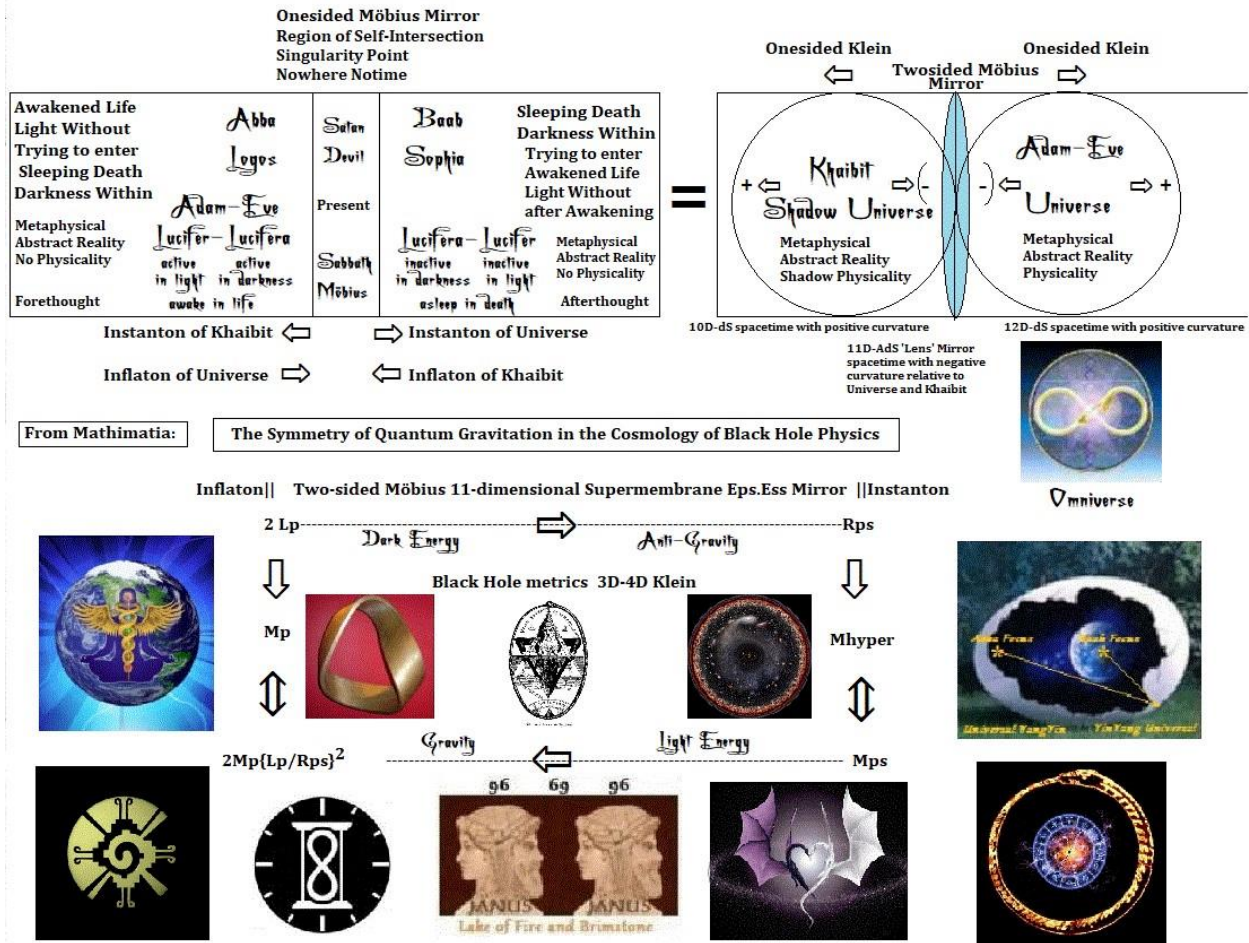

The Schwarzschild metric for $2L_p = 2G_0M_p/c^2$ transforms a 3D Planck-length in the Planck-mass $M_p = \sqrt{\{hc/2\pi G_0\}}$ from the Planck-boson gravitational fine structure constant $1 = 2\pi G_0 M_p^2/hc$.

The Schwarzschild metric for the Weyl-wormhole radius R_{ps} then defines a hypermass M_{hyper} as the conformal mapping of the Planck-mass M_p as $M_{hyper} = \frac{1}{2}\{R_{ps}/L_p\}M_p = \frac{1}{2}\{R_{ps}/L_p\}^2 \cdot M_{ps}$ and where $M_{ps} = E_{ps}/c^2 = hf_{ps}/c^2 = kT_{ps}/c^2$ in fundamental expressions for the energy of Abba- E_{ps} as one part of the supermembrane $E_{ps} \cdot E_{ss}$ in physical quantities of mass m , frequency f and temperature T . c^2 and h and k are fundamental constants of nature obtained from the initializing algorithm of the Mathimatia and are labeled as the 'square of lightspeed c ' and 'Planck's constant h ' and 'Stefan-Boltzmann's constant k ' respectively.

The complementary part of supermembrane $E_{ps}E_{ss}$ is E_{ss} -Baob. E_{ps} -Abba is renamed as 'Energy of the Primary Source-Sink' and E_{ss} -Baob is renamed as 'Energy of the Secondary Sink-Source'.

3)

The primary source-sink and the primary sink-source are coupled under a mode of mirror-inversion duality with E_{ps} describing a vibratory and high energy micro-quantum quantum entanglement with E_{ss} as a winding and low energy macro-quantum energy. It is this quantum entanglement, which allows Abba to become part of Universe in the encompassing energy quantum of physicalized consciousness, defined in the magnetopolar charge.

The combined effect of the applied Schwarzschild metric then defines a Compton Constant to characterize the conformal transformation as: Compton Constant $h/2\pi c = M_p L_p = M_{ps} R_{ps}$.

Quantum gravitation now manifests the mass differences between Planck-mass M_p and Weyl-mass M_{ps} .

The Black Hole physics had transformed M_p from the definition of L_p ; but this transformation did not generate M_{ps} from R_{ps} , but rather hypermass M_{hyper} , differing from M_{ps} by a factor of $1/2 \{R_{ps}/L_p\}^2$.

To conserve supersymmetry, Logos defined an Anti-Instanton as the Inflaton of Khaibit to define the conformal mapping of M_{ps} from Universe into Khaibit as $2M_p \{L_p/R_{ps}\}^2$.

The classical approach described in the Feynman lecture derives the momentum of a moving electron in deriving the volume element for electromagnetic momentum $p = m_{electromagnetic} \cdot v = m_{emr} \cdot v$ with the component of the electron's motion v parallel $g \sin \theta$ and a relativistic velocity $v_{rel} = v\gamma = v/\sqrt{1-[v/c]^2}$ modifying $p_{rel} = p\gamma$

3)

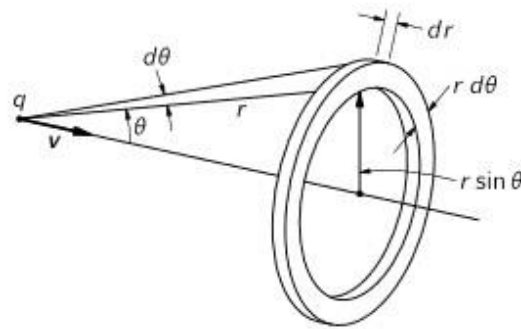
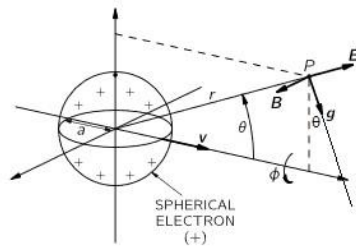

Fig. 28–2. The volume element $2\pi r^2 \sin \theta d\theta dr$ used for calculating the field momentum.



B perpendicular E and v
gsinθ in direction of v
gcosθ transverse direction of v

Fig. 28–1. The fields \mathbf{E} and \mathbf{B} and the momentum density \mathbf{g} for a positive electron. For a negative electron, \mathbf{E} and \mathbf{B} are reversed but \mathbf{g} is not.

For magnetic field $B = v \times E / c^2 = v \cdot E \cdot \sin \theta / c^2$ the momentum density $\epsilon_0 E \times B = \epsilon_0 v \cdot E^2 \sin \theta / c^2$ electric energy density $U_e = \frac{1}{2} \epsilon_0 E^2$ and $E = q / (4\pi \epsilon_0 r^2)$ and $dV = 2\pi r^2 \cdot \sin \theta \cdot d\theta \cdot dr$ for the spacetime interval from some minimum boundary a to ∞ and with $\int 1/r^2 dr = -1/r [\infty, a] = 0 + 1/a = 1/a$ for $a = R_e$ for the waved particle electron

$$\begin{aligned}
 p &= \int \epsilon_0 v (E \sin \theta / c)^2 dV = p_{rel} = \{2\pi \epsilon_0 v \gamma / c^2\} \{q^2 / 16\pi^2 \epsilon_0^2\} \int r^{-2} \cdot \{\sin^3 \theta \cdot d\theta\} \cdot dr = \{v \gamma q^2 / 8\pi \epsilon_0 c^2\} \int r^{-2} \cdot \{\sin^3 \theta \cdot d\theta\} \cdot dr \\
 &= \{v \gamma q^2 / 8\pi \cdot a \cdot \epsilon_0 c^2\} \int \sin^3 \theta \cdot d\theta = \{v \gamma q^2 / 8\pi \cdot a \cdot \epsilon_0 c^2\} \int \{1 - \cos^2 \theta\} \sin \theta \cdot d\theta = \{v \gamma q^2 / 8\pi \cdot a \cdot \epsilon_0 c^2\} \left[\frac{1}{3} \cos^3 \theta \right]_{\cos \theta = [\pi, 0]} \\
 &= \{v \gamma q^2 / 8\pi \cdot a \cdot \epsilon_0 c^2\} \left| -\frac{1}{3} + \frac{1}{3} + 1 \right| = v \gamma q^2 / 6\pi \cdot a \cdot \epsilon_0 c^2 = \mu_0 v \gamma e^2 / 6\pi \cdot R_e \cdot p_{rel} \\
 &= \mu_0 v \gamma e^2 / 6\pi \cdot R_e \text{ for } m_{emr} = \mu_0 \gamma e^2 / 6\pi \cdot R_e = \{4/3\} \frac{1}{2} m_e = \frac{2}{3} m_e > \frac{1}{2} m_e
 \end{aligned}$$

The electromagnetic mass must however be exactly U_e/c^2 by the postulates of Relativity and so the classical derivation must be modified in the particle nature of the electron in its associated quantum mechanical nature.

3)

Using $m_{emr} = m_0 = m_e/2A = \mu_0\gamma e^2/6\pi.R_e = \{4/3\}^{1/2}m_e = 2/3m_e$ defines $A=3/4$ in the $(v/c)^2$ distribution and for a velocity:

$$B^2 = \{v/c\}^2 = -5/6 \pm \sqrt{(19/12)} \text{ for roots } x=0.425 \text{ and } y=-2.092; \text{ with } v_{electron} = 0.65189908 c \text{ in } U_m = (1/2v^2)\mu_0e^2/4\pi R_e = 1/2m_e v^2$$

$$\{4/3\}.U_e/c^2 = \{4/3\}\gamma e^2/8\pi.\epsilon_0 R_e c^2 = \{4/3\}^{1/2}m_e = \{4/3\}.U_m/c^2 = \{4/3\}.\mu_0\gamma e^2/8\pi.R_e = \{4/3\}\gamma ke^2/e^* = \{4/3\}\gamma ke^2.hf^* = (1-1/3)m_e \text{ for an apparent rest mass } 2/3m_e.$$

The corresponding energy level for this mass increase of $1/3m_e$ for a velocity of $0.745 c$ is 2.788×10^{-14} Joules* or 0.17350 MeV* (0.17307 MeV) for a dynamic mass m_e .

The classical electromagnetic mass m_{emr} becomes quantum mechanical in the string-brane sourcesink energy E^* -Gauge photon quantum of the Quantum Big Bang Weylian wormhole. In particular setting the classical electron radius at $(3/2)R_e = \alpha h/(2\pi c.2/3m_e) = \alpha h/2\pi c m_e = 4.1666 \times 10^{-15} m^* (4.15971430 \times 10^{-15} m)$ normalizes the $\{4/3\}$ factor from the classical derivation of the electromagnetic mass for the electron in the mean value for the $A=1/2$ to $A=1$ interval for the β^2 distribution.

$$E^* = E_{ps} = hf_{ps} = hc/\lambda_{ps} = m_{ps}c^2 = (m_e/2e).\sqrt{[2\pi G_0/\alpha hc]} = \{m_e/m_P\}/\{2e\sqrt{\alpha}\} = 1/2R_e c^2 = 1/e^* \dots [Eq.17]$$

Expressing the electromagnetic mass in a series perturbation expansion in decreasing the classical electron size so sets a minimum size for the electron at the Weyl boundary or 'Planck-Stoney Bounce' limit at R_e in $x/c^2 = \lambda_{ps}/2\pi$ for $x = r_{ps}c^2 = 2G_0M_{Hubble} = \text{Wormhole Radius of the Instanton of the quantum gravitational Big Bang creation event.}$

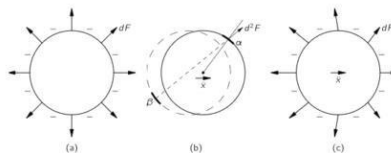

Fig. 28-3. The self-force on an accelerating electron is not zero because of the retardation. (By dF we mean the force on a surface element da , by d^2F we mean the force on the surface element da_a from the charge on the surface element da_b .

The picture is something like this. We can think of the electron as a charged sphere. When it is at rest, each piece of charge repels electrically each other piece, but the forces all balance in pairs, so that there is no net force. [See Fig. 28-3(a).] However, when the electron is being accelerated, the forces will no longer be in balance because of the fact that the electromagnetic influences take time to go from one piece to another. For instance, the force on the piece α in Fig. 28-3(b) from a piece β on the opposite side depends on the position of β at an earlier time, as shown. Both the magnitude and direction of the force depend on the motion of the charge. If the charge is accelerating, the forces on various parts of the electron might be as shown in Fig. 28-3(c). When all these forces are added up, they don't cancel out. They would cancel for a uniform velocity, even though it looks at first glance as though the retardation would give an unbalanced force even for a uniform velocity. But it turns out that there is no net force unless the electron is being accelerated. With acceleration, if we look at the forces between the various parts of the electron, action and reaction are not exactly equal, and the electron exerts a force on itself that tries to hold back the acceleration. It holds itself back by its own bootstraps.

It is possible, but difficult, to calculate this self-reaction force; however, we don't want to go into such an elaborate calculation here. We will tell you what the result is for the special case of relatively uncomplicated motion in one dimension, say x . Then, the self-force can be written in a series. The first term in the series depends on the acceleration \ddot{x} , the next term is proportional to $\ddot{\ddot{x}}$, and so on.¹ The result is

$$F = \alpha \frac{e^2}{a^2} \ddot{x} - \frac{2}{3} \frac{e^2}{c^3} \ddot{\ddot{x}} + \gamma \frac{e^2 a}{c^4} \ddot{\ddot{\ddot{x}}} + \dots, \tag{28.9}$$

where α and γ are numerical coefficients of the order of 1. The coefficient α of the \ddot{x} term depends on what charge distribution is assumed; if the charge is distributed uniformly on a sphere, then $\alpha = 2/3$. So there is a term, proportional to the acceleration, which varies inversely as the radius a of the electron and agrees exactly with the value we got in Eq. (28.4) for m_{elec} . If the charge distribution is chosen to be different, so that α is changed, the fraction $2/3$ in Eq. (28.4) would be changed in the same way. The term in $\ddot{\ddot{x}}$ is independent of the assumed radius a , and also of the assumed distribution of the charge; its coefficient is always $2/3$. The next term is proportional to the radius a , and its coefficient γ depends on the charge distribution. You will notice that if we let the electron radius a go to zero, the last term (and all higher terms) will go to zero; the second term remains constant, but the first term—the electromagnetic mass—goes to infinity. And we can see that the infinity arises because of the force of one part of the electron on another—because we have allowed what is perhaps a silly thing, the possibility of the "point" electron acting on itself.

Modular duality $E_{ps} = hf_{ps} = 1/e^* = \text{Energy primary sourcesink quantum as the Weyl wormhole energy then transforms the electron's self- energy in a decomposition or fine structure of the}$

3)

classical electron radius and as 'spacetime awareness' or 'physical consciousness'. Spacetime awareness $|df/dt|$ acting on a volume of space in a holographic Weyl Bound conformally maps and integrates the quantum gravitational wormhole of wavelength $\lambda_{ps}=10^{-22} \text{ m}^*$ onto the classical electron radius as: $R_{\text{wormhole}}/R_{\text{electron}} = 360/(2\pi \cdot 10^{10})$.

This can be defined as a form of angular acceleration $|\alpha \omega = \alpha\omega| = |df/dt|_e = e^*/V^* = \lambda_{ps}/hc \cdot V^*$ acting on space time volumars or multi-dimensional branes in particle-wave interactions of elementary particles-wavicles. It is so the space occupied and containing dynamical interactions, which render the synthesis of classical physics with quantum mechanics possible; the underpinning nature for those interactions being based on the quantum geometry of the conformal transformations from and to the higher dimensional and closed-open Anti de Sitter (AdS) spacetimes intersecting the lower dimensional and open-closed de Sitter (dS) spacetimes in the mirror duality between two convex manifolds intersected in a mirror-lens of concavity (see quantum gravity diagram above).

$$m_{\text{emr}} = \mu_0 \gamma e^2 / 6\pi \cdot R_e = \{4/3\} \cdot U_e / c^2 = \{4/3\} \gamma e^2 / 8\pi \cdot \epsilon_0 R_e c^2 = \{4/3\}^{1/2} m_e = \{4/3\} \cdot U_m / c^2 = \{4/3\} \cdot \mu_0 \gamma e^2 / 8\pi \cdot R_e = \{4/3\} \gamma k e^2 / e^* = \{4/3\} \gamma k e^2 \cdot hf^*$$

As the electromagnetic mass must however be exactly U_e/c^2 by the postulates of Relativity and so the classical derivation must be modified in the particle nature of the electron in its associated quantum mechanical nature.

A Self-Interaction for the electron in the jerk or time derivative of acceleration d^3x/dt^3 is naturally found in the definition of the classical size of the electron in the wormhole quantization.

The self-interaction of the electron then can be considered as a deformation of the size of the electron using both the classical scale of the particular and the quantum mechanical form in the nature of its intrinsic quantum spin in the form of an angular acceleration given as the time derivative of frequency df/dt .

The extension of Newton's Law in relativistic momentum and energy leads to $dp_{\text{rel}}/dt = d(m_0 \gamma v)/dt = m_0 d(\gamma v)/dt + \gamma v d(m_0)/dt = m_0 d(\gamma v)/dt + \{\gamma v h/c^2\} df/dt = m_0 \gamma^3 \cdot dv/dt + \{\gamma v h/c^2\} df/dt$. It then is the dynamical interaction of the electron with spacetime itself, that changes the classical volume of the electron as a function of df/dt in the membrane space of $2R_e c^2 = \text{Volume} \times \text{Angular}$ radially independent acceleration.

Using this electron self-interaction as a conformal mapping from the Quantum Big Bang 'singularity' from the electric charge in brane bulk space as a magnetic charge onto the classical spacetime of Minkowskian and from the Planck parameters onto the atomic-nuclear diameters in $2R_e c^2 = e^*$ from the Planck length conformally maps the Planck scale onto the classical electron

3)

scale as the classical electron radius and as defined in the alpha electromagnetic fine structure and the related mass-charge definition for the eigen energy of the electron in $m_e c^2 = k e^2 / R_e$.

The pre-Big Bang 'bounce' of many models in cosmology can be found in a direct link to the Planck-Stoney scale of the 'Grand-Unification-Theories'. In particular it can be shown, that the Square root of Alpha, the electromagnetic fine structure constant, multiplied by the Planck length results in a Stoney-transformation factor $L_P \sqrt{\alpha} = e/c^2$ in a unitary coupling between the quantum gravitational and electromagnetic fine structures.

$G_0 k = 1$ for $G_0 = 4\pi\epsilon_0$ and representing a conformal mapping of the Planck length onto the scale of the 'classical electron' in superposing the lower dimensional inertia coupled electric charge quantum 'e' onto a higher dimensional quantum gravitational-D-brane magnetopole coupled magnetic charge quantum 'e*' = $2R_e \cdot c^2 = 1/hf_{ps} = 1/E_{Weyl \text{ wormhole}}$ by the application of the mirror/T duality of the supermembrane $E_{ps}E_{ss}$ of heterotic string class HE(8x8).

Also in a model of quantum relativity (QR), there is a quantization of exactly 10^{10} wormhole 'singularity-bounce' radii defining the radian-trigonometric Pi ratio as $R_{\text{wormhole}}/R_{\text{electron}} = 360/2\pi \cdot 10^{10}$ or $10^{10} = \{360/2\pi\} \{R_e/r_{\text{wormhole}}\}$ as a characteristic number of microtubules in a conformal mapping from the classical electron space onto the 'consciousness' space of the neuron-cell intermediate between the Hubble scale of 10^{26} m and the Planck scale of 10^{-35} m as geometric mean of 10^{-4} to 10^{-5} meters.

It is so the geometry of the architecture of the microtubules and the nature of their construction utilizing the pentagonal quasi-crystalline pattern in its application for maximizing the compression of information in the Fibonacci geometrical pattern-sequencing. This then results in the conformal mapping of this geometry as a quantum geometry and defining physical consciousness as a conformal mapping of the quantum of spacetime in the form of Weylian 'Quantum Big Bang' wormholes of the cosmogenesis.

<https://cosmosdawn.net/index.php/en...he-weyl-curvature-hypothesis-of-roger-penrose>

The 4/3 factor from the classically derived electromagnetic mass appears in the quantum geometry of the subatomic particles, namely in the different quark content for the positively charged proton and the electrically overall neutral neutron, both displaying an internal charge distribution, however.

For the Proton, one adds one (K-IR-Transition energy) and subtracts the electron-mass for the dquark level and for the Neutron one doubles this to reflect the up-down-quark differential. An electron perturbation subtracts one $2-2/3=4/3$ electron energy as the difference between 2 leptonic rings from the proton's 2 up-quarks and $2-1/3=5/3$ electron energy from the neutron' singular up-quark to relate the trisected nucleonic quark geometric template. This is revisited below.

3)

Proton $m_p = u.d.u = K.KIR.K = (939.776 + 1.5013 - 0.5205 - 0.1735) \text{ MeV}^* = 940.5833 \text{ MeV}^* (938.270 \text{ MeV})$.

Neutron $m_n = d.u.d = KIR.K.KIR = (939.776 + 3.0026 - 1.0410 + 0.1735) \text{ MeV}^* = 941.9111 \text{ MeV}^* (939.594 \text{ MeV})$.

This is the ground state from the Higgs-Restmass-Induction-Mechanism and reflects the quarkian geometry as being responsible for the inertial mass differential between the two elementary nucleons. All ground state elementary particle masses are computed from the Higgs Scale and then become subject to various fine structures.

But modular string duality defines the Inverse Energy of the wormhole as the quantum of physical consciousness in units of the product of the classical electron diameter and the proportionality between energy and mass in the Maxwell constant $c^2 = 1/\epsilon_0$ and the inverse of the product between electric permittivity $\epsilon_0 = 1/120\pi c$ and magnetic permeability $\mu_0 = 120\pi/c$ for 'free space' impedance: $Z_0 = \text{electric field strength } E / \text{magnetic field strength } H = \sqrt{(\mu_0/\epsilon_0)} = c\mu_0 = 1/c\epsilon_0 = 120\pi$.

Coulomb Electro Charge $e = L_P \cdot \sqrt{\alpha \cdot c^2} \leftrightarrow 2R_e \cdot c^2 = e^*$ (Star Coulomb Magneto Charge)

$$e^* = 2R_e c^2 = 2ke^2/m_e = e^2/2\pi\epsilon_0 m_e = \alpha hc/\pi m_e \text{ with Alpha-Variation}$$

$$(1.6021119 \times 10^{19} / 1.60217662 \times 10^{-19})^2 = 0.99991921... \text{ for the calibration}$$

$$\{R_e m_e\} = \mu_0 e^2 / 4\pi = (2.8179403267 \times 10^{-15} \text{ m})(9.10938356 \times 10^{-31} \text{ kg}) = (2.818054177 \times 10^{-15} \text{ m})(9.109015537 \times 10^{-31} \text{ kg}) = (10^{-7})(1.60217662 \times 10^{-19} \text{ C})^2$$

$$= [2.56696992 \times 10^{-45}] \cdot [1.001671358] [1.003753127] \cdot (0.99991921...) \text{ (mkg)}^*$$

$$= [2.56696992 \times 10^{-45}] \cdot [1.002711702]^2 \cdot [0.99991921...] = 2.580701985 \times 10^{-45} \text{ {mkg}}^* =$$

$$(2.77777... \times 10^{-15} \text{ m}^*) (9.290527148 \times 10^{-31} \text{ kg}^*) = \mu_0 e^2 / 4\pi \text{ for } e = 1.606456344 \times 10^{-19} \text{ C}^* \text{ for the quantum mechanical electron and adjusted in the [SI/*] alpha variation [mkg/C}^2] = \text{Alpha}$$

$$\text{Variation } \alpha_{\text{var}} \text{ in } \{R_e m_e \cdot \alpha_{\text{var}}\}_{\text{SI}} = \{\alpha_{\text{var}} \cdot \mu_0 e^2 / 4\pi\}_{\text{SI}} = \{R_e m_e\}^* = \{\mu_0 e^2 / 4\pi\}^*$$

Decreasing the electronic charge quantum from $1.60217662 \times 10^{-19} \text{ C}$ to $1.602111893 \times 10^{-19} \text{ C}$ so calibrates the SI-unitary measurement system with the star based * unitary mensuration system in the alpha variation in a reduced classical electron radius of $R_e = 2.773142866 \times 10^{-15} \text{ m}$ for an increased electron effective rest mass of $m_e = 9.255789006 \times 10^{-31} \text{ kg}$ or for $(R_e m_e) = (\mu_0 e^2 / 4\pi) = 2.566762525 \times 10^{-45} \text{ mkg}$.

The electron has no known [substructure](#)^[1175] and it is assumed to be a [point particle](#) with a [point charge](#) and no spatial extent.^[9] In [classical physics](#), the angular momentum and magnetic moment of an object depend upon its physical dimensions. Hence, the concept of a dimensionless electron possessing these properties contrasts to experimental observations in Penning traps which point to finite non-zero radius of the electron. A possible explanation of this paradoxical situation is given

3)

below in the "[Virtual particles](#)" subsection by taking into consideration the Foldy Wouthuysen transformation (See <https://en.wikipedia.org/wiki/Electron>)

The issue of the radius of the electron is a challenging problem of the modern theoretical physics. The admission of the hypothesis of a finite radius of the electron is incompatible to the premises of the theory of relativity. On the other hand, a point-like electron (zero radius) generates serious mathematical difficulties due to the [self-energy](#) of the electron tending to infinity.^[76] These aspects have been analyzed in detail by [Dmitri Ivanenko](#) and [Arseny Sokolov](#).

Observation of a single electron in a [Penning trap](#) shows the upper limit of the particle's radius is 10^{-22} meters.^[77] Also an upper bound of electron radius of 10^{-18} meters^[78] can be derived using the [uncertainty relation](#) in energy.

There *is* also a physical constant called the "[classical electron radius](#)", with the much larger value of 2.8179×10^{-15} m, greater than the radius of the proton. However, the terminology comes from a simplistic calculation that ignores the effects of [quantum mechanics](#); in reality, the so-called classical electron radius has little to do with the true fundamental structure of the electron.^{[79][note.5]}

Note that the defined maximum scale for the electron in the Penning Trap is consistent with the defined size of the wormhole radius $r_{ps} = 10^{-22}/2\pi$ meters as minimum spacetime configuration of the Instanton. The 'point particular' electron of Quantum Electrodynamics and its point-like particle fields, so crystallizes naturally from the theory of the string-membrane classes. The classical electron radius R_e has much to do with the quantum mechanical electron addressed by Richard Feynman in the linked lecture.

There is, however, one fundamental objection to this theory and to all the other theories we have described. All particles we know obey the laws of quantum mechanics, so a quantum-mechanical modification of electrodynamics has to be made. Light behaves like photons. It is not 100 percent like the Maxwell theory. So the electrodynamic theory has to be changed. We have already mentioned that it might be a waste of time to work so hard to straighten out the classical theory, because it could turn out that in quantum electrodynamics the difficulties will disappear or may be resolved in some other fashion. But the difficulties do not disappear in quantum electrodynamics. That is one of the reasons that people have spent so much effort trying to straighten out the classical difficulties, hoping that if they *could* straighten out the classical difficulty and *then* make the quantum modifications, everything would be straightened out. The Maxwell theory still has the difficulties after the quantum mechanics modifications are made. See From the Feynman Lecture.

The quantum effects do make some changes—the formula for the mass is modified, and Planck's constant $h/2\pi$ appears—but the answer still comes out infinite unless you cut off an integration somehow—just as we had to stop the classical integrals at $r=a$. And the answers depend on how you stop the integrals. We cannot, unfortunately, demonstrate for you here that the difficulties are really basically the same, because we have developed so little of the theory of quantum mechanics

3)

and even less of quantum electrodynamics. So you must just take our word that the quantized theory of Maxwell's electrodynamics gives an infinite mass for a point electron. It turns out, however, that nobody has ever succeeded in making a *self-consistent* quantum theory out of *any* of the modified theories. Born and Infeld's ideas have never been satisfactorily made into a quantum theory. The theories with the advanced and retarded waves of Dirac, or of Wheeler and Feynman, have never been made into a satisfactory quantum theory. The theory of Bopp has never been made into a satisfactory quantum theory. So today, there is no known solution to this problem. We do not know how to make a consistent theory—including the quantum mechanics—which does not produce an infinity for the self-energy of an electron, or any point charge. And at the same time, there is no satisfactory theory that describes a non-point charge. It is an unsolved problem.

In case you are deciding to rush off to make a theory in which the action of an electron on itself is completely removed, so that electromagnetic mass is no longer meaningful, and then to make a quantum theory of it, you should be warned that you are certain to be in trouble. There is definite experimental evidence of the existence of electromagnetic inertia—there is evidence that some of the mass of charged particles is electromagnetic in origin.

It used to be said in the older books that since Nature will obviously not present us with two particles—one neutral and the other charged, but otherwise the same—we will never be able to tell how much of the mass is electromagnetic and how much is mechanical. But it turns out that Nature *has* been kind enough to present us with just such objects, so that by comparing the observed mass of the charged one with the observed mass of the neutral one, we can tell whether there is any electromagnetic mass. For example, there are the neutrons and protons. They interact with tremendous forces—the nuclear forces—whose origin is unknown. However, as we have already described, the nuclear forces have one remarkable property. As far as they are concerned, the neutron and proton are exactly the same.

The *nuclear* forces between neutron and neutron, neutron and proton, and proton and proton are all identical as far as we can tell. Only the little electromagnetic forces are different; electrically the proton and neutron are as different as night and day. This is just what we wanted. There are two particles, identical from the point of view of the strong interactions, but different electrically. And they have a small difference in mass. The mass difference between the proton and the neutron—expressed as the difference in the rest-energy mc^2 in units of MeV—is about 1.3 MeV, which is about 2.6 times the electron mass. The classical theory would then predict a radius of about $\frac{1}{2}$ to $\frac{1}{3}$ the classical electron radius, or about 10^{-13} cm. Of course, one should really use the quantum theory, but by some strange accident, all the constants— $2\pi's$ and $h/2\pi's$, etc.—come out so that the quantum theory gives roughly the same radius as the classical theory.

The only trouble is that the *sign* is wrong! The neutron is *heavier* than the proton.

Nature has also given us several other pairs—or triplets—of particles which appear to be exactly the same except for their electrical charge. They interact with protons and neutrons, through the

3)

so-called —strongl interactions of the nuclear forces. In such interactions, the particles of a given kind—say the π -mesons—behave in every way like one object *except* for their electrical charge. In Table [28-1](#) we give a list of such particles, together with their measured masses. The charged π -mesons—positive or negative—have a mass of 136.9 MeV, but the neutral π^0 -meson is 4.6 MeV lighter. We believe that this mass difference is electromagnetic; it would correspond to a particle radius of 3 to 4×10^{-14} cm. You will see from the table that the mass differences of the other particles are usually of the same general size.

Now the size of these particles can be determined by other methods, for instance by the diameters they appear to have in high-energy collisions. So the electromagnetic mass seems to be in general agreement with electromagnetic theory, if we stop our integrals of the field energy at the same radius obtained by these other methods. That is why we believe that the differences do represent electromagnetic mass.

You are no doubt worried about the different signs of the mass differences in the table. It is easy to see why the charged ones should be heavier than the neutral ones. But what about those pairs like the proton and the neutron, where the measured mass comes out the other way? Well, it turns out that these particles are complicated, and the computation of the electromagnetic mass must be more elaborate for them. For instance, although the neutron has no *net* charge, it *does* have a charge distribution inside it—it is only the *net* charge that is zero. In fact, we believe that the neutron looks—at least sometimes—like a proton with a negative π -meson in a —cloudll around it, as shown in Fig. [28-5](#). Although the neutron is —neutral,ll because its total charge is zero, there are still electromagnetic energies (for example, it has a magnetic moment), so it is not easy to tell the sign of the electromagnetic mass difference without a detailed theory of the internal structure.

3)

Table 28–1 Particle Masses

Particle	Charge (electronic)	Mass (MeV)	Δm^1 (MeV)
n (neutron)	0	939.5	
p (proton)	+1	938.2	-1.3
π (π -meson)	0	135.0	
	± 1	139.6	+4.6
K (K-meson)	0	497.8	
	± 1	493.9	-3.9
Σ (sigma)	0	1191.5	
	+1	1189.4	-2.1
	-1	1196.0	+4.5

¹ $\Delta m = (\text{mass of charged}) - (\text{mass of neutral})$.

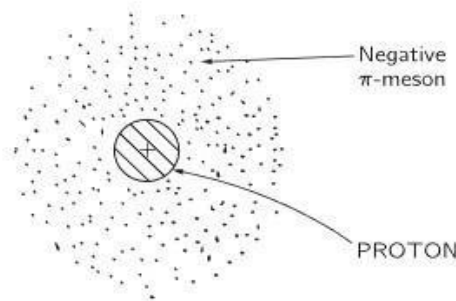

Fig. 28–5. A neutron may exist, at times, as a proton surrounded by a negative π -meson.

The negatively charged pion cloud of Feynman and Yukawa can be substituted by the inner negatively charged mesonic Inner Ring in the quantum geometry of the quarks based on colour charged or chromodynamic double charged kernels surrounded by an Inner Mesonic and an outer Leptonic Ring wave structure asymptotically confined by a magneto charged region known as the classical radius of the electron. The rings are oppositely charged to the kernel quarks. They however remain coupled in the kernel trisection say as the protons $udu=K.KIR.K=K(K+IR)K$ or the neutron's $dud=KIR.K.KIR=(IR+K)K(K+IR)$ except when they experience the electro-weak decays.

3)

-13-

Higgs-Bosonic Template for the Calabi-Yau

Wavequark Proton $K.KIR.K = u.d.u$

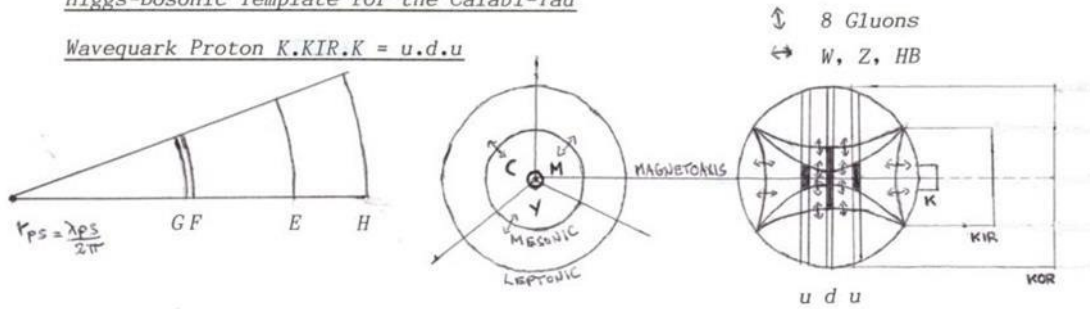

The importance of Kernel-Symmetry so is evidenced in the differentiation of the quarkian permutations and specifying for example the $KKIRKOR$ quark state uds as a tripartite symmetry of $u.d.s$ (least stability as SNI -decaying Σ^0 ' resonance) and $u.s.d$ (EMI -stable Σ^0 particle) and $d.u.s$ (WNI -most stable Λ^0 particle).

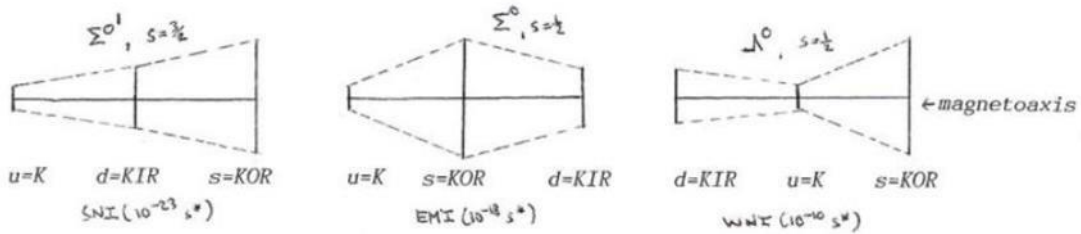

3)

The Universal Quantum Geometric Matter-AntiMatter Template

Matter AntiNeutrino Kernel KKK
Matter Core KKK = CMY

Mesonic Matter
Inner Ring IR

Matter Template
CyanMagentaYellow
CMY=MYC=YCM
Red'Green'Blue'²
RRGGBB=GGBRR=BRRGG

Leptonic Matter
Outer Ring OR

K=u-core quark
KIR=d-wave quark
KOR=s-wave quark

ElectroCharge $3(-\frac{1}{3}) = -1$ for IR & OR
MagnetoCharge RGB = 0 for IR & OR
ElectroCharge $3(+\frac{2}{3}) = +2$ for Kernel KKK
MagnetoCharge RRGGBB = 0 for Kernel KKK

AntiMatter Neutrino Kernel KKK
AntiMatter Core KKK = CYM

Mesonic AntiMatter
Inner Ring IR

AntiMatter Template
CyanYellowMagenta
CYM=YMC=MCY
Red'Blue'Green'²
RRBBGG=BBGRR=GRRBB

Leptonic AntiMatter
Outer Ring OR

K-bar=u-core antiquark
KIR=d-wave antiquark
KOR=s-wave antiquark

ElectroCharge $3(+\frac{1}{3}) = +1$ for IR & OR
MagnetoCharge BGR = 0 for IR & OR
ElectroCharge $3(-\frac{2}{3}) = -2$ for Kernel KKK
MagnetoCharge BBGGRR = 0 for Kernel KKK

MagnetoCharge = ColourCharge = GluonCharge

Matter OR
Outer Ring B
BBB=Black

Unified Kernel = Gluon for Strong Nuclear Interaction
In 8 KKK Permutations of the MagnetoCharge:
{BBB=Pure massive eigenstate in E=mc²
BBW; BWB; WBB; BWB; WWB; WWB;
WWW=Pure radiative eigenstate in E=hf
3-quark content: hyperons-baryons-nucleons
And in 4 KK Permutations:
{BB; BW; WB; WW}
quark-antiquark content: mesons
Unified Kernel = (Anti)Neutrino for
Weak Nuclear Interaction & 0 ElectroCharge

Matter Weakon W-minus
ElectroCharge -1 for OR
Muon μ^- or Electron e^-
MagnetoCharge = 0 for AntiNeutrino Core

Clockwise Righthand
Anticlockwise Lefthand
Quantum Spin

$e^- + \bar{\nu}_{electron} = W^- [+1] = \mu^- + \bar{\nu}_{muon}$

OR-Flip = $W^- [+1] + \text{GraviPhoton} [-1]$

AntiMatter OR
Outer Ring W
WWW=White

AntiMatter Weakon W-plus
ElectroCharge +1 for OR
AntiMuon μ^+ or Positron e^+
MagnetoCharge = 0 for Neutrino Kernel

$e^+ + \nu_{electron} = W^+ [-1] = \mu^+ + \nu_{muon}$

OR-Flip = $W^+ [-1] + \text{GraviPhoton} [+1]$

Vortex-Potential-Energy VPE = ZPE
OR-Flip + OR-Flip
(Core +OR)VPE
YCM+YMC=(CM-B)YY(B=MC)
BYBY=GMMG=RCCR
YBBY=CRRC=MGGM
RGB+RBG=(GB-C)RR(C=BG)

Neutron \Rightarrow Proton + Electron + Electron AntiNeutrino
Basic Neutron Beta-Minus Decay: $n^0 [-\frac{1}{2}] \Rightarrow p^+ [-\frac{1}{2}] + e^- [-\frac{1}{2}] + \bar{\nu}_e [+1/2]$
d[-1/2]u[+1/2]d[-1/2](stable in nucleus) \Rightarrow u[+1/2]d[-1/2]d[-1/2](free) \Rightarrow u[+1/2]d[-1/2]d*[-1/2] (IR-OR Oscillation)
 \Rightarrow u[+1/2]d[-1/2][u[-1/2].W^- [+1].GP[-1]] \Rightarrow u[-1/2]d[+1/2]u[-1/2]+e^- [-1/2]+ $\bar{\nu}_e$ [+1/2] \Rightarrow udu[-1/2]+electron-OR[-1/2]+ $\bar{\nu}_e$ [+1/2]

Muon \Rightarrow Electron + Electron AntiNeutrino + Muon Neutrino
Basic Muon Weak Decay: $\mu^- [-1/2] \Rightarrow e^- [-1/2] + \bar{\nu}_e [+1/2] + \nu_\mu [-1/2]$
OR^- [-1/2] (free) \Rightarrow OR^- [-1/2] (KKK-OR Oscillation) \Rightarrow (ν_μ .OR)^- [-1/2].(W^- [+1].GP[-1]) \Rightarrow e^- [-1/2] + $\bar{\nu}_e$ [+1/2] + ν_μ [-1/2]

Only lefthanded matter particles and only righthanded antimatter particles participate in the Weak Nuclear Interaction in a fundamental Nonparity between Matter and Antimatter and as a consequence of the magnetocharged gauge interaction particles suppressing any naturally occurring antimatter in an inflationary and 'Big Bang prior' radiation-antiradiation grand symmetry 'Goldstone Boson' superstring unification:
RGB/SourceSink Photon(+1)+{BGR/SinkSource Photon(+1)+RestMass Photon(-1)}+RGB/Gluon(+1) +BGR/Graviton(-2)=0 and in coupling to the templates for Matter YCM and Antimatter MCY.

The suppressed SinkSource Photon (Devil/AntiGod Particle) with the 'Dark Matter/Energy Particle' descriptive in the definition of Consciousness/Space Awareness transforms into a Scalar Higgs Gauge Boson to form a recreated Supersymmetry in the Unified Field of Quantum Relativity or UFOQR.
The Gauge Photon RGB(+1) can also be described in the high energy vibratory part Eps of the supermembrane EpsEss with the Gauge Photon BGR(+1) its low energy winded conjugative part Ess.
The Scalar Higgs AntiNeutrino (RGB)⁴[0] + (RGB)²[+1/2] creates the Tau AntiNeutrino $\bar{\nu}_\tau$ [+1/2] in Leptonic Energy Resonance.
The Scalar Higgs Neutrino (BGR)⁴[0] + (BGR)²[-1/2] creates the Tau Neutrino ν_τ [-1/2] in Anti-Leptonic Energy Resonance.

3)

There actually exist three uds-quark states which decay differently via strong, electromagnetic and weak decay rates in the uds (Σ^0 Resonance); usd (Σ^0) and the sud (Λ^0) in increasing stability.

This quantum geometry then indicates the behaviour of the triple-uds decay from first principles, whereas the contemporary standard model does not, considering the u-d-s quark eigenstates to be quantum geometrically undifferentiated.

The nuclear interactions, both strong and weak are confined in a 'Magnetic Asymptotic Confinement Limit' coinciding with the $R_e = ke^2/m_e c^2$ and in a scale of so 3 Fermi or 2.8×10^{-15} meters. At a distance further away from this scale, the nuclear interaction strength vanishes rapidly.

Subtracting the Ring-VPE (3L) gives the basic nucleonic K-State as 939.776 MeV*. This excludes the electronic perturbation of the IR-OR oscillation.

For the Proton, one adds one (K-IR-Transition energy) and subtracts the electron-mass for the dquark level and for the Neutron one doubles this to reflect the up-down-quark differential. An electron perturbation subtracts one $2-2/3=4/3$ electron energy as the difference between 2 leptonic rings from the proton's 2 up-quarks and $2-1/3=5/3$ electron energy from the neutron' singular up-quark to relate the trisected nucleonic quark geometric template.

Proton $m_p = u.d.u = K.KIR.K = (939.776 + 1.5013 - 0.5205 - 0.1735) \text{ MeV}^* = 940.5833 \text{ MeV}^* (938.270 \text{ MeV})$.

Neutron $m_n = d.u.d = KIR.K.KIR = (939.776 + 3.0026 - 1.0410 + 0.1735) \text{ MeV}^* = 941.9111 \text{ MeV}^* (939.594 \text{ MeV})$.

This is the ground state from the Higgs-Restmass-Induction-Mechanism and reflects the quarkian geometry as being responsible for the inertial mass differential between the two elementary nucleons. All ground state elementary particle masses are computed from the Higgs Scale and then become subject to various fine structures.

(Continued on Part 4)

Received February 22, 2019; Accepted March 31, 2019